



Description SBR Q1+ Kits

Clearfox SBR Q1+Kits operate according to the SBR-Process (Sequencing batch reactor) with integrated aerobic sludge stabilisation.

There are different stages of the treatment process (buffer, biological treatment, sludge treatment with storage) integrated within one tank. The system operates regardless of the tank material or shape. That process flexibility means that any type of tank can be used for the SBR Q1+.

Only a partial baffle is needed to retain large inorganic particles in the first chamber. This baffle can be open at the bottom.

If there is a mechanical or manual screen at the SBR system inlet, then a baffle is not necessary. A Screen should be used for any system if the system is bigger than 500 PE.

The system is designed dimensioned according to the guidelines of the DWA-A 131 and DWA-A 222.

The PIA GmbH proofed, tested and certified the system by a 38 weeks cleaning efficiency test equal to the 12566-3 test for small wastewater treatment plants.

Cleaning efficiency

The cleaning efficiency was approved and certified at the PIA GmbH in Aachen over 38 weeks (according to the 12566-3 38 weeks test for small waste water treatment plants). It was tested with domestic waste water.

- COD < 50 mg/l
- BOD < 10 mg/l
- NH4-N < 1 mg/l
- SS < 20 mg/l

Scope of delivery

Clearfox SBR Q1+Kits consist of an aeration system, airlift pumps, an air compressor, an air distribution manifold with electronic/magnetic valves and a control unit.

➤ **Maintenance free disc diffuser mounted on a PE manifold pipe; amount of diffusers and size of manifold according to plant design**

- EPDM Membrane; A = 0,55m²; d=275 mm; chemical resistance
- Mounting material



➤ **Maintenance free airlift for clearwater**

- Special pre-cleaning function for clearwater airlift to ensure that no solids get out of the system
- PVC with plug connection
- Free ball passage from 50 up to 150 mm

- **Control unit installed in a powder coated cabinet**
 - Sizes of the cabinet depends on the plant siz
 - Pressure sensor controlled microprocessor technology
 - Solanoid valve manifold
 - Graphic display, illuminated, 6 lines
 - Electronic operating log, with 52 weeks storage
 - USB interface for reading operating data
 - Automatic commissioning test
 - optional
 - Expandable for UV sterilization
 - Expandable for phosphate elimination
 - Expandable for elimination of trace-resistance trace substances

- **Maintenance free, two stage side channel air compressor**
 - Capacity according to the dimensioning of the system size
 - Associated silencer
 - Corrosion protected



PE	hydraulic Loading m ³ /day	organic Loading KG BOD/day	tankvolume m ³	max. water depth m	Compressor size KW	dimension airliftpumps Mm	power consumption KWh/day	diameter connecting tube mm	paletts for transport no.
100	15	6	40	2,00	1,1	75	13,2	25	2
150	22,5	9	60	2,50	1,5	100	18	25	2
200	30	12	80	2,50	1,5	100	18	25	2
250	37,5	15	100	2,50	3	100	36	32	3
300	45	18	120	2,50	3	100	36	32	3
350	52,5	21	140	3,00	4,5	150	54	40	3
400	60	24	160	3,00	4,5	150	56,25	40	3
450	67,5	27	180	3,00	5,5	150	66	40	4
500	75	30	200	3,00	5,5	150	68,75	40	4
550	82,5	33	220	3,00	6	150	75	40	4
600	90	36	240	3,00	6	150	78	40	4
650	97,5	39	260	3,00	9	150	108	40	5
700	105	42	280	3,00	9	150	108	40	5
750	112,5	45	300	3,00	9	150	112,5	40	5
800	120	48	320	3,00	9	150	112,5	40	5
850	127,5	51	340	3,00	11	150	132	40	6
900	135	54	360	3,00	11	150	132	40	6
950	142,5	57	380	3,00	11	150	137,5	40	6
1000	150	60	400	3,00	11	150	137,5	40	6

Benefits for Clearfox SBR Q1+ Kits

No odor	Easy installation and handling
Low running costs	Sludge stabilization/sludge treatment
High performance with high quality, Made in Germany	Stable and very robust process technology

Additional equipment

The **Clearfox SBR Q1+** system can be upgraded to any required effluent standard. No matter if it is a phosphorous elimination, hygienisation or even trace-resistance trace substances must be eliminated.

➤ Phosphorous elimination

At the end of the cleaning process a precipitant is added to the reactor.
This takes the phosphate out and store it in the activated sludge.

- Peristaltic dosing pump 0,2 – 4,5 l/h
 - 230 V +/- 10%, 50/60 Hz; 5 VA
 - IP65
 - Capacity adjustable via potentiometer
- Suction lance with level control

➤ Chlorine disinfection

The chlorine disinfection also will be handled with a dosingpump.
The cleaned water will be pumped by the airliftsystem to a retention tank. During the filling is also the dosing of the chlorine to this tank.

- Peristaltic dosing pump 0,2 – 4,5 l/h
 - 230 V +/- 10%, 50/60 Hz; 5 VA
 - IP65
 - Capacity adjustable via potentiometer
- Suction lance with level control
- Size of the retention tank (customer side)
50% of the daily amount of wastewater

ground view

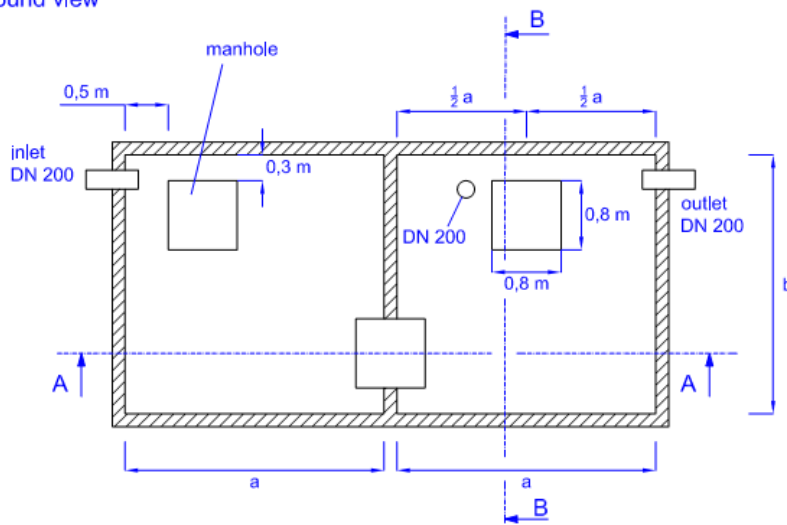

cut drawing B - B

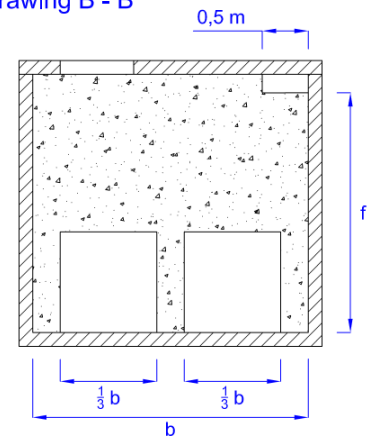

cut drawing A - A

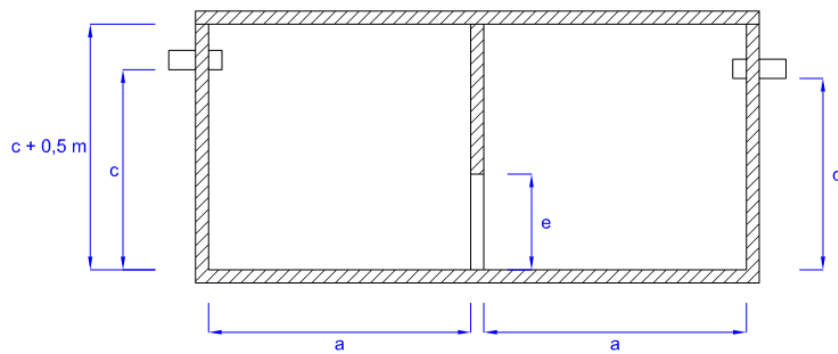

PE	a	b	c	d	e	f
	m	m	m	m	m	m
100	3,30	3,00	2,20	2,10	1,00	2,30
150	3,40	3,50	2,70	2,60	1,25	2,80
200	4,00	4,00	2,70	2,60	1,25	2,80
250	4,40	4,50	2,70	2,60	1,25	2,80
300	4,80	5,00	2,70	2,60	1,25	2,80
350	4,70	5,00	3,20	3,10	1,50	3,30
400	5,30	5,00	3,20	3,10	1,50	3,30
450	5,50	5,50	3,20	3,10	1,50	3,30
500	5,60	6,00	3,20	3,10	1,50	3,30
550	6,10	6,00	3,20	3,10	1,50	3,30
600	6,20	6,50	3,20	3,10	1,50	3,30
650	6,70	6,50	3,20	3,10	1,50	3,30
700	6,60	7,00	3,20	3,10	1,50	3,30
750	7,10	7,00	3,20	3,10	1,50	3,30
800	7,10	7,50	3,20	3,10	1,50	3,30
850	7,50	7,50	3,20	3,10	1,50	3,30
900	7,50	8,00	3,20	3,10	1,50	3,30
950	7,90	8,00	3,20	3,10	1,50	3,30
1000	8,30	8,00	3,20	3,10	1,50	3,30